

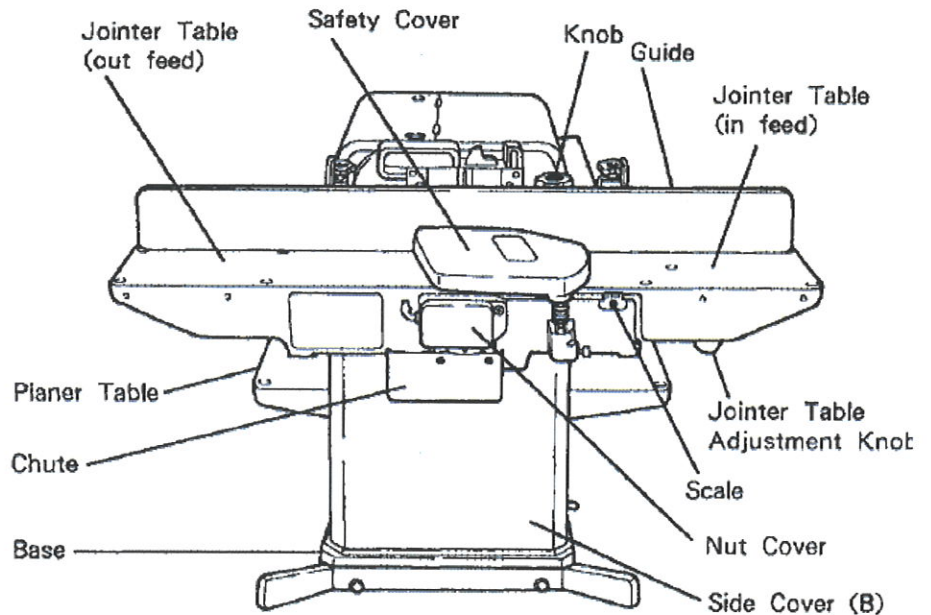

**STUDY GUIDE**



## JOINTER

1. Keep the guard over the blade at all times.
2. Do not adjust the rear table.
3. Use jointer on EDGE grain only. No end grain or face grain.
4. The finish cut is always 1/10th inch. The first cut to remove rough edges can be 1/8th inch.
5. Do not use short boards or narrow, thin pieces on the jointer.
6. Ask for permission for any use of the jointer other than edge grain.
7. NO SMALL BOARDS.